

TORSION AXLE GEARS • STEEL WHEELS • DISC BRAKES

CMS

PARTS CATALOG 2024

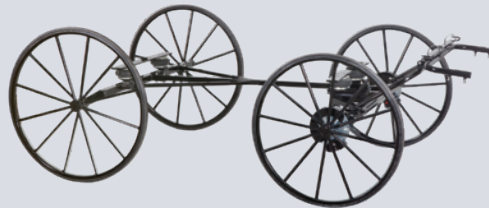

CONTENTS:

Torsion Gears..... 4-7
 Undercarriage Weight
 Comparison 6
 Wheels & Accessories..... 8-9
 Torsion Gear Accessories
 & Replacement Parts..... 10-12
 Miscellaneous Buggy Parts..... 13

Automotive Paints & Primers 13
 Air Bag Kit & Parts 14
 Air Compressor & Parts 15
 Disc Brakes & Parts..... 16-18
 Brake Fittings 19
 Tax Form & Order Form 20-23



Welcome!

Welcome to our 2024 catalog showing the full line of Amish and Mennonite carriage parts manufactured at our facility in Bird-in-Hand, Pennsylvania. While many of our products remain the same, you will notice some changes and additions as we strive to serve you better.

We would like to take time to thank first and foremost, our Heavenly Father for the blessings He bestows upon us every day! Secondly, we thank you, our valued customers for continued support as we continue to strive for excellence in every aspect of business: innovation, quality & service! We sincerely appreciate the valuable feedback you provide, as it helps us improve our products.

Our goal while assembling this catalog was to make it easier for you to place orders, so we hope you find that simplicity as you browse through these pages. Please call us if you have any questions about our products.

About Us

A family owned and operated business since 1979, nestled in the heart of Lancaster County, Carriage Machine Shop manufactures quality carriages and parts, while offering friendly customer service.

Where to Find Us

Carriage Machine Shop, LLC
250 Maple Ave.
Bird-in-Hand, PA 17505
717-397-4079
717-397-4085 (fax)

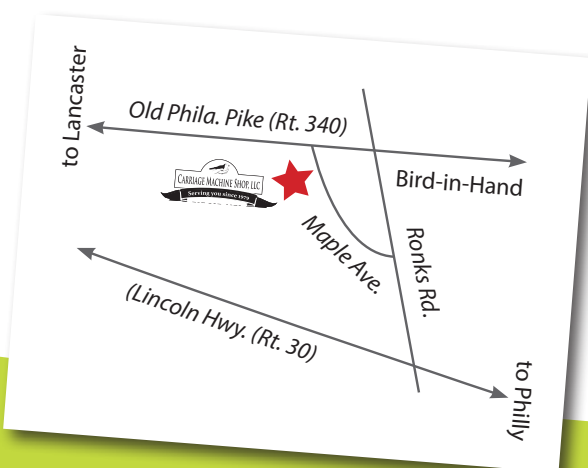

Terms & Conditions

RETURNS:

No returns will be accepted unless authorized by a representative of CMS LLC. Merchandise will be credited when it is in our warehouse. Return shipping costs must be prepaid. A 25% restocking fee applies to all returned or refused merchandise. No returns will be accepted after 30 days unless upon agreement. Items to be returned must be in original condition.

SHIPPING DAMAGES:

Shipping damages must be reported within 24 hours of delivery. Please keep your item and all packing materials for possible inspection. If the item returned under this clause is found to be perfect and in full working order, it will be returned to you and an administration fee of 15% of the purchase price plus the shipping cost back to you will be charged.

12 MONTH LIMITED WARRANTY:

Parts from CMS LLC are warranted for a period of 12 months from the date of manufacture, subject to the terms & conditions as follows:

- CMS LLC will repair or replace any part which is defective or becomes faulty within a period of 12 months from purchase, provided it is returned to us, shipping paid, and that the part has only been used in the normal and correct way. We reserve the right to change/improve specifications from time to time without notice. **Any repairs or modifications performed by anyone other than CMS LLC automatically voids this warranty.**
- Labor: The owner may at his option and with CMS LLC approval, have the defective part shipped to the shop for repair. All labor and material costs for repair at the shop will be borne by CMS LLC, but the owner assumes all shipping costs. **Should the owner choose a source other than CMS LLC to repair the part, this warranty will be voided and CMS LLC no longer assumes responsibility for the part.**
- Warranty applies to original owner only.
- **Steel wheels have a 6-Year Pro-Rated Limited Warranty.** See page 9 for details.

TERMS:

Wholesale accounts get 1% discount when paid in 10 days, net 30. Retail customers payment is due upon receipt.

NOTICE:

Carriage Machine Shop will not be liable or responsible for any type of accident that may arise from any of our products. Use all of our products at your own risk.



Improving Since 1979.

Carriage Machine Shop opened its doors in 1979 to begin manufacturing 2-wheeled carts for the pleasure driving market. As that market began to diminish around 2006, we shifted our focus to increase Amish and Mennonite buggy parts manufacturing. Since that time, we have spent considerable energy in developing and refining the steel wheel, undercarriages, and disc brakes. Enjoy a quiet drive through the history of CMS product improvements...



CMS Disc Brakes

CMS began manufacturing steel wheels & installing disc brakes on pleasure carriages.

2006

Installed an imported British disc brake system on an Amish carriage, which lasted only two years under rugged use.

2008

After extensive research, we partnered with an American company to design a **disc brake system to fit Amish carriages**.

2010

Stainless steel discs were getting hot and eating up the brake pads, so we **switched from stainless steel to regular steel** discs.

2011

Upgraded from 3/16" disc to 1/4" disc. The **thicker disc eliminated some noise** and had better wear.

2012

Switched pad material due to screeching brakes.

2013

To remedy issues with drag and rattle, CMS **developed a 3 spring pad system**. This helped, but didn't completely resolve.

2014

Added new style pull back springs to calipers which eliminated rattle & dragging brakes.

Old disc covers trapped & amplified noise. We found that a more open design significantly reduced road noise.

2015

Changed caliper mount to eliminate movement on the axle caused by vibration and to make installation easier.

2016

Celebrated 40 years in business with gratitude to our customers!

2019

Switched to **plastic disc covers** to reduce weight & price.

2022

CMS Steel Wheel & Undercarriages

CMS purchased Bellcrown Carriages who manufactured steel wheels in England for over 30 years for the pleasure carriage industry.

Responding to requests for a quieter ride, CMS began developing a torsion axle undercarriage system with airbag suspension and steel wheels.

Strengthened the outside wheel channel to prevent flat spots.

Tested the torsion axle w/ airbags, steel wheels & disc brakes **on our personal carriages**. Friends & neighbors began asking for a test drive which led to our first orders.

Added a zinc-rich epoxy primer to the powder coating process to prevent rusting underneath the top coat.

Investigated and adjusted welding temperature and how it relates to occasional spoke breakage.

Redesigned the regular long hub for a **cleaner look & lighter weight**.

Modified our welding technique to remedy broken welds on the outside steel tire.

Developed NEW style torsion to **allow about 200% more range of motion**, which provides a smoother ride.

Reduced weight by redesigning the torsion and the front fifth wheel.

Switched to **Jasper rubber** on all wheels with rubber tire, which is proving to be more durable.

Started branding as CMS



Implemented **Pivot Up Shaft Stop** to keep shafts from hitting carriage.

Started **stamping date** into wheels for tracking purposes.

Switched to **aluminum shaft fronts** to reduce weight and prevent a price increase.

Introduced the new **CMS Spring Tree**.



#5200 Torsion Gear

Available w/ Airbags or Rubber Shocks



AVAILABLE TO FIT YOUR TOP



AVAILABLE TO SHIP ON A 3' X 6' SKID



USE PAGE 21 FOR EASY ORDERING



(pictured) Gear w/ rubber torsion axle • 5200-AB Airbag Suspension • 5532 Disc brakes w/ 5100-P covers • 5300 Pivot-up steel shafts • 5502-RFR 36" x 40" steel wheels w/ rubber & flat steel rim • 409 lbs.

NOW STANDARD

Pivot-up Shaft Stop

Now you can fold up your shafts without worrying that it will rub against your carriage top.

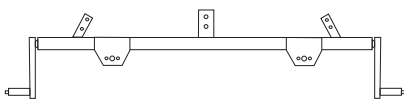

5200-AB

Medium airbags in front & rear, choice of spindles. Most popular setup for most any size carriage or small surrey. Specify box length & width.

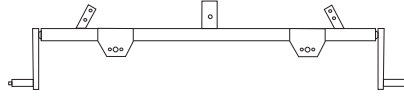

5201-AB

Medium airbags in front & rear, choice of spindles. Rear airbags are set up wider for spring wagons, surreys, or pick-ups. Specify hub centers for length and rear airbag centers.

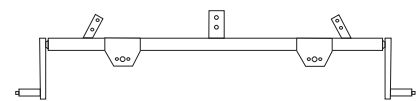

5204-AB

Set-up for market wagons, spring wagons, or surreys. Spring in front, medium airbags in rear, choice of spindles. Specify center of front spring to center of rear axle, and rear airbag centers.

5200-RS Rubber shocks instead of airbags

5201-RS Rubber shocks instead of airbags

5204-RS Rubber shocks instead of airbags



(pictured) Gear w/ rubber torsion axle • 5200-RS Rubber Shock Suspension • 5532 Disc brakes w/ 5100-P covers • 5300 Pivot-up steel shafts • 5502-RFR 36" x 40" steel wheels w/ rubber & flat steel rim • 409 lbs.



Find more Gear Options on p. 7

Spindles Available

Regular 1 1/8" long spindle



Regular 1 1/8" short spindle



CMS 1 1/4" short spindle for CMS hubs.



Torsion Gear w/ Spring



AVAILABLE TO FIT YOUR TOP



AVAILABLE TO SHIP
ON A 3' X 6' SKID



USE PAGE 21 FOR
EASY ORDERING

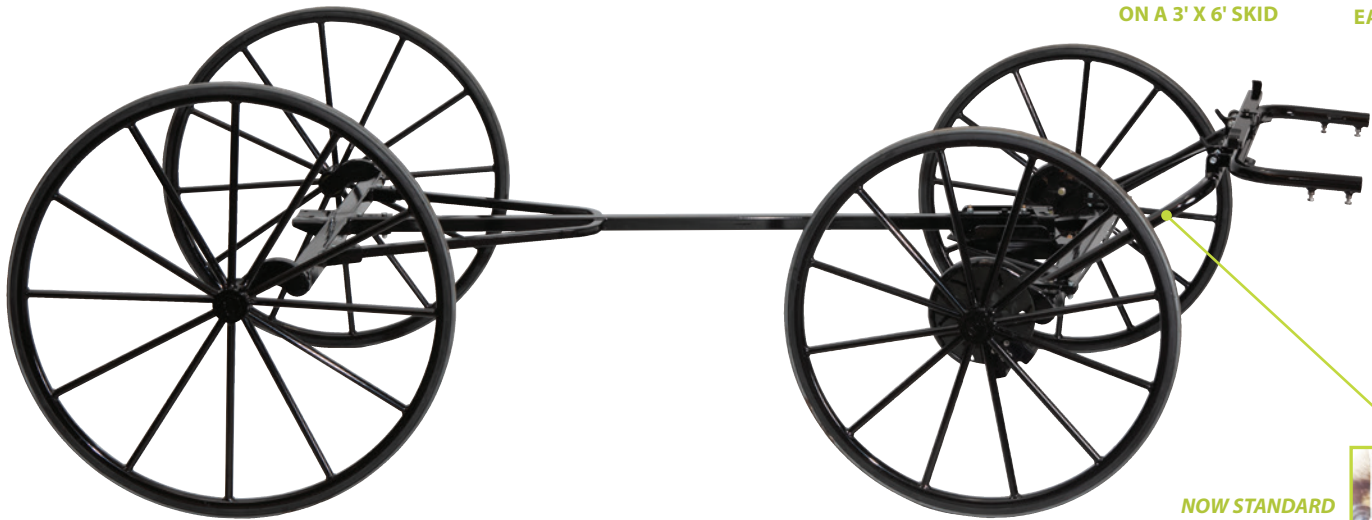

(pictured) Gear w/ rubber torsion axle • 5205 Spring attachment • 5532 Disc brakes w/ 5100-P covers • 5300 Pivot up steel shafts • 5502-RFR 36" x 40" Steel wheels w/ rubber & flat steel rim • Weight 465 lbs (weight includes springs)

NOW STANDARD

Pivot-up Shaft Stop

Now you can fold up your shafts without worrying that it will rub against your carriage top.



Set-ups:

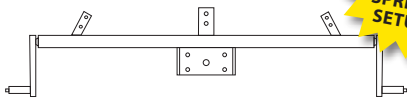

5205 Set-up for single or double carriage with springs (front & rear). Rear spring mounts behind the axle to shorten wheel base. Wooden block not needed to mount springs. *Specify spring centers.*

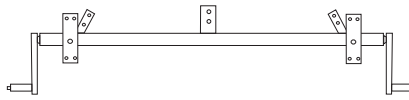

5207 Set-up for side springs on pickups, spring wagons, or surreys. *Specify center of front spring to center of rear axle, and rear spring centers.*

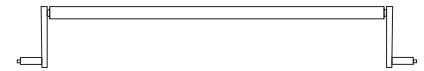

Custom Cart Axle w/Torsion 5214 Choose spindles, mounting brackets & axle length. *Specify cart body width, wheel track width, and what type of attachment to mount body.*

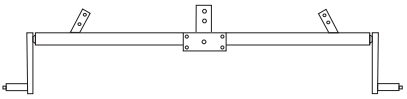

5206 Set-up for single or double carriage with springs (front & rear). Rear spring mounts on top of axle. Wooden block not needed for rear axle. *Specify spring centers.*

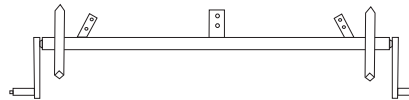

5208 Set-up for double half elliptic springs on market wagons. *Specify center of front spring to center of rear axle.*

***NOTE: Spring Gears are made to fit 1 1/2" springs. Springs are NOT included.**

Shaft Attachments

Tabs for regular wooden or fiberglass shafts



Disc Brakes

w/ covers on CMS 1 1/4" hub



Fifth Wheel

Wooden block not needed to mount spring



NEW DESIGN

5205 Rear Spring Mount

Wooden block not needed to mount spring



NEW DESIGN

Straight Axle w/ Spring



AVAILABLE TO FIT YOUR TOP



AVAILABLE TO SHIP ON A 3' X 6' SKID



USE PAGE 21 FOR EASY ORDERING



Steel axle eliminates need for axle clips and is easy to clean!

(pictured) 5210 CMS Straight Axle (does not have torsion axle) • 5532 Disc Brakes w/ 5100-P covers • 5300 Pivot-up steel shafts • 5502-RFR 36" x 40" steel wheels w/ rubber & flat steel rim • Weight 421.5 lbs

NOW STANDARD

Pivot-up Shaft Stop

Now you can fold up your shafts without worrying that it will rub against your carriage top.



Not interested in torsion axle? ...but still want the benefits of CMS 1 1/4" hub system, pivot-up shafts, disc brakes, and steel wheels? This gear is for you!

Set-ups:

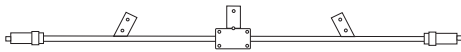

5210 Straight Axle Gear

Set-up for single carriage with springs. *Specify spring centers.*

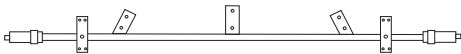

5211 Straight Axle Gear w/ side springs in rear

Set-up for side springs on pickups, spring wagons, or surreys. *Specify center of front spring to center of rear axle, as well as rear spring centers.*

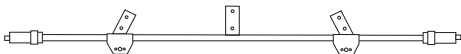

5212-AB Straight Axle Gear w/ Airbags in rear

Set-up for market wagons, pickups, spring wagons, or surreys. *Specify center of front spring to center of rear axle, as well as rear airbag centers.*

Rubber Shock...
5212-RS



Rubber shocks may be substituted for airbags

*Weights INCLUDE EZ Ride Springs w/ mounting brackets, etc.



Comparing Weight to a Traditional Gear

	TRADITIONAL	CMS UNDERCARRIAGE
suspension & axles	1" straight axles w/ EZ Ride Springs	CMS Straight Axle w/ 1 1/4" axle stubs & leaf spring attachment <ul style="list-style-type: none"> • Larger bearings allow easier rolling & last longer • Eliminates need for axle clips
wheels	Wooden w/ channel rubber & flat steel	Steel w/ rubber & flat steel <ul style="list-style-type: none"> • Low maintenance & durable • Avoid annual re-hooping
brakes	7" drum	Disc w/ covers <ul style="list-style-type: none"> • Smooth & consistent brake action • Uniform pad movement prevents wheels from sliding
shafts	Fiberglass	Pivot up steel <ul style="list-style-type: none"> • Eliminates downward pressure on horse's back (Testing has shown a 75% reduction) • Rust-free stainless shaft fronts
TOTAL WEIGHT	405 LBS.*	421.5 LBS.*

Disc Brakes

Installed on front axle (pictured). Also available on rear axle.



Find more Gear Options on p. 7

Fifth Wheel Spring Mount

Wooden block NOT needed to mount spring



NEW DESIGN

Rear Axle Spring Mount

Wooden block is NOT needed to mount spring.



Gear Options At-A-Glance

● = standard
○ = optional
NA = not available



Torsion w/ Air Bag Torsion w/ Spring Straight Axle w/ Spring

Rubber torsion axle	●	●	NA
Straight back torsion	○	●	NA
Regular angle torsion	●	○	NA
Steel perch	●	●	●
Air bags or rubber shocks (<i>front & rear</i>)	●	NA	NA
Air bags or rubber shocks (<i>rear, spring in front</i>)	NA	○	○
Heavy duty fifth wheel w/ nylon wafer	●	●	●
Steel wheels	○	○	●
CMS 1 1/4" spindles (<i>only fits the CMS 1 1/4" hub & disc brakes</i>)	○	○	●
1 1/8" long spindles	○	○	NA
1 1/8" short spindles	○	○	NA
CMS disc brakes	○	○	●
Disc covers	○	○	●
Hydraulic drum brakes (<i>only available on 1 1/8" long or short spindles</i>)	○	○	NA
Pivot up shafts	○	○	●
Tabs for regular shafts	○	○	NA
Pivot up shaft stop	●	●	●
Custom shaft attachments	○	○	NA
Attachment for side springs	NA	○	○
Attachment for double half elliptic springs	NA	○	NA
Made to fit any carriage top (<i>Call us with specs</i>)	●	●	●
Durable powder coating	●	●	●
5th Wheel Stop	○	○	○

Write your order notes here
so when you re-order, it's easy!

Installation Tips:



Airbag Gear

- **Recommended air pressure** will vary due to weight and style of carriage top being used. 15 to 20 PSI is recommended for Lancaster County.
- When installing a **#5200 gear**, you will want to **hook up the airbags side to side**, meaning left rear and left front airbag to one gauge, then the same for the right side.
- Very important! Anytime you install airbags, **be sure to cut the ends of the tubing straight**. If they are not cut straight, they will leak!
- **Use Loctite Thread Sealant 545 (CMS part# 5451)** on all air fitting threads.
- **Check all wheel bearings** installed by CMS **for tightness to your specs**. We tighten them at the shop, but as you know, wheel bearings can loosen once broken in.

Spring Gear

- When installing a **#5205 gear** or any of our gears with spring, you will need to **supply your own springs, spring blocks, clip bars, bolts, and hangers**.
- **Check all wheel bearings** installed by CMS **for tightness to your specs**. We tighten them at the shop, but as you know, wheel bearings can loosen once broken in.

Disc Brakes

- **Use Loctite Thread Locker 263 (CMS part# 5450)** on all disc brake bolts, especially on the disc and #5342 Caliper Bracket. Use sparingly!
- **Do NOT overtighten bolts** when installing Disc Brakes. You will only stress the bolt and cause premature failure.
- **CMS Disc Brakes work best** when used with a **Master Cylinder without a check valve**. CMS #5559 already has the check valve removed. When using a master cylinder from a vendor other than CMS, please remove the check valve.

Wheels



Rigorous powder coat process for maximum coating adhesion.

✓ Please specify size when ordering.



PARTNER KEYSTONE COATING KEEPS YOUR WHEELS PROTECTED

Every Carriage Machine wheel receives the same process at Keystone Coating.

They first **blast the wheels using steel grit** to ensure the metal is cleaned and ready for coating. The workhorse of protection is a **zinc-rich epoxy primer coating** applied to the wheel, creating a barrier from rust and other corrosive materials. This has been **proven to greatly extend the life by up to 4 times!**

Finally, a **top coat of polyester powder coating** is applied giving your wheels a beautiful high-gloss finish with approximately **6-8 mils of protection** from the harsh elements.

Other services offered by Keystone Coating:

- Blasting
- Masking of parts to protect certain areas from powder
- Quality control personnel
- Value added services (i.e. packaging, minor assembly, etc)
- Delivery
- Environmentally responsible option vs. wet paint



Steel Wheel – Long Hub <i>fits PA 1" or 1 1/8" long spindle axle</i>		Weight
5500-NONE	No Rubber or Steel	29 lbs
5500-ROH	1 ¼ Half Round Jasper Rubber	34 lbs
5500-ROF-J	1 ¼ Flat Top Jasper Rubber	34 lbs
5500-ROF-T	1 ¼ Flat Top TBP Rubber	34 lbs
5500-RFR	1 ¼ Flat Top TBP Rubber and 3/8 x 1 3/8" Flat Steel Rim	51 ½ lbs
5500-RFR-LP	Low Profile TBP Rubber and 3/8 x 1 3/8" Flat Steel Rim	51 ½ lbs
5500-RHR	1 ¼ Flat Top TBP Rubber and 1 1/8" Half Round Steel Rim	51 ½ lbs
5500-RHR-LP	Low Profile TBP Rubber and 1 1/8" Half Round Steel Rim	51 ½ lbs



Steel Wheel – Flush Hub <i>fits PA 1" or 1 1/8" short spindle axle</i>		Weight
5501-NONE	No Rubber or Steel	29 lbs
5501-ROH	1 ¼ Half Round Jasper Rubber	34 lbs
5501-ROF-J	1 ¼ Flat Top Jasper Rubber	34 lbs
5501-ROF-T	1 ¼ Flat Top TBP Rubber	34 lbs
5501-RFR	1 ¼ Flat Top TBP Rubber and 3/8 x 1 3/8" Flat Steel Rim	51 ½ lbs
5501-RFR-LP	Low Profile TBP Rubber and 3/8 x 1 3/8" Flat Steel Rim	51 ½ lbs
5501-RHR	1 ¼ Flat Top TBP Rubber and 1 1/8" Half Round Steel Rim	51 ½ lbs
5501-RHR-LP	Low Profile TBP Rubber and 1 1/8" Half Round Steel Rim	51 ½ lbs



Steel Wheel – CMS 1 ¼" Hub		Weight
5502-NONE	No Rubber or Steel	29 lbs
5502-ROH	1 ¼ Half Round Jasper Rubber	34 lbs
5502-ROF-J	1 ¼ Flat Top Jasper Rubber	34 lbs
5502-ROF-T	1 ¼ Flat Top TBP Rubber	34 lbs
5502-RFR	1 ¼ Flat Top TBP Rubber and 3/8 x 1 3/8" Flat Steel Rim	51 ½ lbs
5502-RFR-LP	Low Profile TBP Rubber and 3/8 x 1 3/8" Flat Steel Rim	51 ½ lbs
5502-RHR	1 ¼ Flat Top TBP Rubber and 1 1/8" Half Round Steel Rim	51 ½ lbs
5502-RHR-LP	Low Profile TBP Rubber and 1 1/8" Half Round Steel Rim	51 ½ lbs

CMS Channel Profile Rubber
Rubber fits CMS steel wheels only. Sold by the coil.



1 ¼" Flat Top 5189



1 ¼" Round Top 5190



1 ¼" Low Profile Flat Top 5191



Graber & Canadian custom hubs available upon request.

Weights based on 40" wheel with 12 spokes

Wheel Accessories



Hubcap Wrench
5080
For CMS 1 1/4" hubcap



O-Ring
5082
For CMS 1 1/4" hubcap



Hubcap - CMS 1 1/4"
5017
Fits CMS 1 1/4" hub.
Painted black.



Hub Cap - EZ Pin
5070
Fits PA long hub wheels.
Powder coated black.



Hubcap - Flush 5076
Fits PA flush hub wheels.
Painted black.



Oil Seal
CMS 1 1/4"
5286



Oil Seal Driver for
CMS 1 1/4" oil seal
5289



CMS 1 1/4" Hub
w/ Flange for
Fiberglass Wheel
5320
Raw steel. w/ hubcap



Oil Seal
52841"
52851 1/8"



Bearings
5282 small (A6075)
52801" (07093)
52811 1/8" (07100)
52831 1/4" CMS



Hub Cover 5294
for CMS 1 1/4" hub.
Protects oil seal from
horse hair, etc. Set of 2.

Bearing
Races



5292
LM67010



5291
07196



5290
A6157



We are now using bearings from
PEER BEARING. Extensive testing is
showing improved performance.

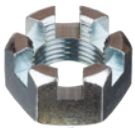

Axle Nut for
CMS 1 1/4" Axle
5168



3/16" thick axle
washer for CMS
1 1/4" axle
5170



Cenpeco Bearing
Grease 5276



Axle nut for
Regular Axle
5167



Axle washer for
regular axle
5169



Cotter Pins
5296 For 1 1/8" axle
5295 For 1 1/4" axle



CMS Steel Wheel PRO-RATED WARRANTY



Time elapsed

2 yr	24 month
3 yr	25-36 month
4 yr	37-48 month
5 yr	49-60 month
6 yr	61-72 month

Coverage

FULL
50%
30%
20%
10%

CMS Steel Wheel Coverage includes any defect found in the structural soundness of the wheel, under normal use (such as broken spokes, flat spots in channel, cracked hub, etc.) This does NOT include the outer rim, whether it be rubber or steel.

2 yr	24 month
------------	----------

FULL

CMS Outer Rim Coverage on all rubber & steel rim (installed by CMS).

Torsion Gear Accessories & Replacement Parts

Perch 5217
Powder coated black.
Specify length and type of gear (air bag or EZ spring).



Plastic Cap for Perch 3050
1 1/2 x 11 ga tubing



3/8" x 2 3/4" Perch Bolt 3025
Grade 8



Perch Plates
Powder coated black



For Airbag Gear **5218**



For EZ Spring **5219**



Perch Plate, Rear 5227

Mudsplasher Rods

Powder coated black



For regular tab **5160**



For pivot up shafts **5161**



TG Fifth Wheel Top Plate for Spring 5220



Fifth Wheel Wafer 5228



TG Fifth Wheel Top Plate for Spring w/ stops 5235



Kingpin Bolt 5171
For torsion gear



TG Fifth Wheel Top Plate for Airbag/Rubber Shock 5224



TG Fifth Wheel Top Plate for Airbag/Rubber Shock w/ stops 5234

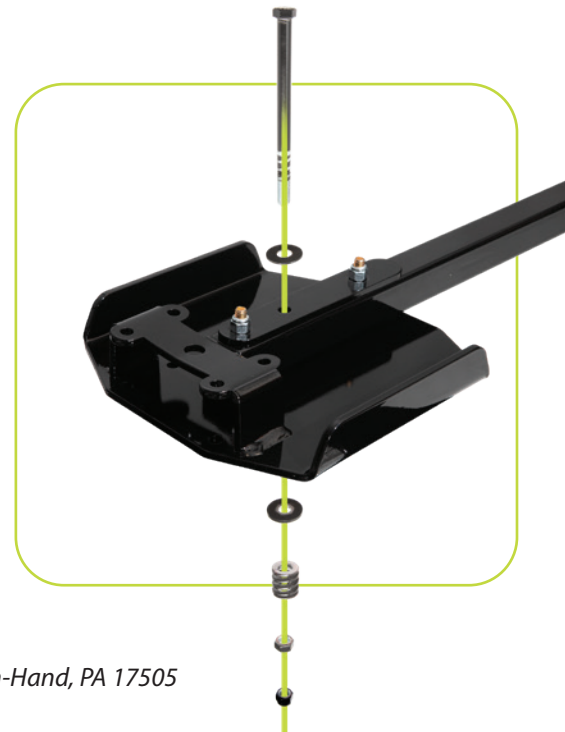

Pivot-Up Shaft Complete 5300

Includes 5260 Steel Single Tree or you may upgrade to the new Spring Tree 5298-B or 5298-C. Powder coated black.



"I lost 7.5 lbs!"

Shaft Fronts 5302

74" long, aluminum, powder coated, 1 pair. Weighs 10.5 lbs.

Pivot-up Shaft Receivers

Powder coated black.



For Flex Tree or Soft Tug
5033



Pivot-up Shaft Heel
5034



For CMS Steel Single Tree or Spring Tree
5261



Steel Single Tree 5260

36" overall length. Stainless steel hooks. Powder coated black.

The CMS Spring Tree provides a soft start to your ride and reduces jerking while going uphill. This sleek style has very few components which eliminates rattle and rust. An adapter 5301 is available to mount on wooden or fiberglass shafts.



CMS Spring Tree w/ Black hooks
5298-B Stainless steel hooks.
Powder coated black.



CMS Spring Tree w/ Chrome hooks
5298-C Electro-polished stainless
steel hooks. Powder coated black.

Please note: Warranty on spring trees may be voided if safety straps are not installed.

Strap w/ SS buckle
5145 For spring tree,
single tree, and evener.



Spring Tree Mounting
Bracket - Bolt on
5301 Can be installed on
wooden or fiberglass shafts.



Single Tree Washer
5262 Delrin plastic.
For single trees on
CMS pivot-up.



Single Tree
Bolt
3017

Pivot-up receiver shown
w/ 5298-C (installed)





Pivot-up Shaft Bushing 5257
Delrin plastic. Replacement part for the pivot point of your steel pivot-up shafts.



Pivot-up Plate w/ 1" Tabs 5037
Fits pivot-up plates welded to the axle. Allows easy conversion from pivot-up shafts to regular double hitch pole. Powder coated black.



1" Shaft Spacer 5259
Delrin plastic. 3/8" hole.



Weld-on Pivot up Plate 6103
Raw steel



Brackets to install pivot-up on 1" or 1 1/8" regular axle 5263



Rubber Shock Plate 5159 to install rubber shock on #5200 gear.



Weld-on Airbag Mount 5230 Raw steel



3/8" x 1 3/4" Hexhead Bolt Grade 8 3024 For pivot up



3/8" x 1" Hex Bolt 3023 Stainless steel



Socket Head Flat Screw - 3/8" x 1" 3034 Stainless



3/8" x 1 1/2" Elevator Bolt Grade 5 3022 Stainless steel



3/8" x 1 1/2" Socket Head Cap Screw Grade 8 3021



1 1/8" long spindle 5270
Fits PA long hub.



1 1/8" short spindle 5271
Fits PA flush hub.



Regular 1 1/4" short spindle 5010
For CMS hubs.

Metal Shafts 5036
Steel heel with stainless steel shaft fronts. Powder coated black.



Adjustable Eyes 5149
For double hitch pole.



Pole 5138
Double hitch, aluminium for pivot-up

Pole 5140
Double hitch, aluminium with adjustable heel to fit shaft tabs from 44" centers to 42" centers. Powder coated black. Adjustable pole length to fit a variety of horses and ponies.



Total weight is 52 lbs.



Pole Spring & Chain Assembly 5139



Emergency Kit 5480
Everything you need to make a small repair on the road to get home safely.

Miscellaneous Buggy Parts

DISCONTINUED



Halogen Light Bracket
Powder coated black.
2010



Light Bracket w/ Bridle Hook
Powder coated black.
2004



Light Bracket for Buggy w/ Bridle Hook
Powder coated black.
2260



Mirror Bracket
Powder coated black.

2148-S short (4 1/8")
2148-M medium (5 1/8")
2148-L long (6 1/8")



Mirror Bracket
Stainless steel
2235-M medium (5 1/8")
2235L long (6 1/8")



Window Holdup
Powder coated black.
Fits Amish carriage boxes.
2228-N narrow 1 1/4"
2228-W wide 2 1/4"

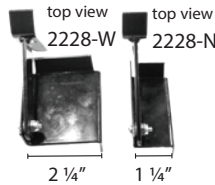

Window Holdup - Mennonite Style
2228-M
Powder coated black.
Fits most Mennonite carriage boxes.



Roller Irons 5279
With nylon rollers. Very quiet & durable.
Used for steel rims or rubber tire.



Mudsplasher Strips
5178
1/8" x 1" aluminium strip.
Specify length: 29 1/2", 32", 35", 37", 39"



Mudsplasher J-Clips
Stainless, with bolts
5172 7/8"

Extra Bolts, Nuts & Washers for Mudsplasher J-Clips
5173-BP 50 pc. pack



Bio Plastic Eyelette
5174 For J-Clip



Spring Link
1/4" x 1" metal with radius ends. Raw steel.
2250 .. 1 1/4" hole center
2251 .. 1 1/2" hole center
2252 2" hole center

Buggy Jack 2039
Black powder coated. Makes wheel washing a breeze.



Automotive Paints & Primers



DTR & DTM Black Urethane Primer HP5311
Direct to rust / rust converter. Very high build acrylic urethane primer. Wood grain, etc. filler. Direct to metal application. 3-4 hour sanding time @ 80 degrees. 1 hour pot life. 4:1 mixing ratio w/ HH3100. 1 1/2 gal kit



HP662 DTA Black 2K Epoxy Primer HP662
Direct to anything application with excellent adhesion. 10 day topcoat window. Not a sanding primer. Direct to rust, has rust converter. 2 gal kit



DURAFLINT 9044 - Black Paint HC9044
Excellent gloss and color retention. 8 hour assembly time, 2 week full cure. 6 hour pot life. 10 year gloss. Can be used in direct to metal application. Comparable to U280. 1 gal kit

Air Bag Kit & Parts

Market Wagon Kit

Reduce vibration and noise in a market wagon or spring wagon. Install on rear axles. Standard kit fits 1" and 1 1/8" axle. Also available for 1 1/4" axle. *Specify axle size when ordering.*



with Airbags 5087-AB



with Rubber Shocks 5087-RS



Easily convert a noisy market wagon to a quieter ride.



Air Bag Bracket 5092
Powder coated black



Air Bag Bracket Adjuster 5089
Powder coated black



Air Bag Bracket Axle Mount 5090
Powder coated black



Poly Tubing 5400
1/4" poly tubing used on all CMS air bag systems.



Air Bag medium 5086



Rubber Shock 5360



5200-ABKIT

This kit of items is used on our 5200-AB Torsion Gear, but can also be used on other gears. Check the list below to be sure this kit includes everything you need.

- 3023 Hex Bolt - 3/8" x 1" - stainless steel (8)
- 3034 Socket Head Flat Screw - 3/8" x 1" (8)
- 3101 Split Washer 3/8" Stainless steel (8)
- 5028 Air pump (1)
- 5029 Air pressure gauge, bracket (2)
- 5086 Air bag, medium (4)
- 5390 Air pressure gauge 60 psi (2)
- 5398 Brass tee, 1/8" NPT (2)
- 5399 Watts Air fill valve (2)
- 5400 Poly tubing, 1/4" (per foot) (25)
- 5401 Legris tee, 1/4" poly (2)
- 5403 Legris elbow, 1/8" NPT x 1/4" poly (2)
- 5410 Legris elbow, 1/4" NPT x 1/4" poly (4)



Air Gauge 5390
60 PSI



Air Gauge Panel Mount 5392
100 PSI



Air Pump 5028
Hand-operated. Included with all gears and kits with air bags. Style and color may vary.



Watts Air Fill Valve 5399
1/8" NPT. Use with standard hand pump or tire chuck.



Brass Tee 5398
1/8" NPT



Reducing Bushing 5405
1/4" NPT x 1/8" NPT. Brass.



Legris Tee 5401
For 1/4" poly tubing



Legris Tee 5402
1/8" NPT x 1/4" poly



Legris Elbow 5410
1/4" NPT x 1/4" poly (fits into airbag)



Legris Elbow 5403
1/8" NPT x 1/4" poly



Legris Straight 5404
1/8" NPT x 1/4" poly



1/4" Tubing Clip 5183



Self Drilling Screw Panhead #8 x 1/2" 3035 Stainless steel



5200-RSKIT

This kit of items is used on our 5200-RS Torsion Gear, but can also be used on other gears. Check the list below to be sure this kit includes everything you need.

- 3034 Flat Socket Head Cap Screw 3/8" x 1" (8)
- 3021 Flat Socket Head Cap Screw 3/8" x 1 1/2" SS (4)
- 3022 Elevator Bolt - 3/8" x 1 1/2" Grade 2 (4)
- 5360 Rubber Shock (4)
- 5159 Rubber Shock Plate (4)
- 3018 Nylon Lock Nut - Zinc plated 3/8" (16)
- 3005 3/8" Fender Washer (4)



Air Gauge Bracket 5029
Powder coated black



Mounting Plate 5195
for panel mount gauge



Mounting Plate 5196
for air toggle switch

Air Compressor & Parts



NEW!

Air Manifold Assembly w/ 2 regulators and air compressor 5192

- Recommended for carriages and buggies with equal weight front and back
- Left side air bags go to left gauge
- Right side air bags go to right gauge
- Simply adjust to preferred air pressure
- Regulators maintain air pressure in airbags and air compressor starts automatically when more air is needed and power is on
- Backup manual air fill valve to charge air reservoir if needed

Air Manifold Assembly w/ 2 regulators, air compressor, and check valves 5193

- Recommended for spring wagons, pick ups, cab wagons, surreys with more weight on the rear axle than on the front.
- Rear airbags go to one gauge
- Front airbags go to one gauge
- Simply adjust to preferred air pressure
- Regulators maintain air pressure in airbags and air compressor starts automatically when more air is needed and power is on
- Check valves help stabilize the load by restricting air from moving between airbags
- Backup manual air fill valve to charge air reservoir if needed

NEW!



Air Manifold Assembly w/ 2 paddle switches 5194

- Recommended for carriages and buggies with equal weight front and back
- Left side air bags go to left gauge
- Right side air bags go to right gauge
- Fill and release switch for easy air pressure adjustment
- When power is on, air compressor starts automatically when more air is needed
- Backup manual air fill valve to charge air reservoir if needed



Victor Compact Tire Inflator 5383
12 volt air compressor



Pressure Switch 5382
Fixed Setpoint Pressure Switch, wire lead, 1/8 NPT Male Connection, 50 PSI Setpoint off 30 PSI Setpoint on



Paddle Switch 5381
Paddle Seat Air Valve 3/16 barb



Pressure Regulator 5380
Clippard Pressure Regulator, #10-32 Mainfold Mount, Knurled Knob, 10-50 psig



Threaded Brass Bushing 5406
1/2 NPT male x 1/8" NPT female



Compression Straight 5431
w/ 1 nut. 1/8" NPT male to 3/16" tube



Compression Straight 5428
w/ 1 nut. 1/8" NPT female to 3/16" tube



Compression Straight 5429
w/ 1 nut. 1/4" NPT male to 3/16" tube



Plug 5432
w/ hex drive. 1/8" NPT w/ sealant.



Rubber Ball 5384
for manifold check valve, 5/16".



Compression Spring 5385
for manifold check valve, 1" long x 0.3 diameter.



SS Face Plate 5192A-1
16 ga #4 polish, for manifold w/ regulators.



SS Face Plate 5194A-1
16 ga #4 polish, for manifold w/ paddle switches.

Disc Brakes & Parts

Kits contain parts for 2 wheels. Order 2 kits for 4 wheels. Master cylinder is not included in kits, but can be purchased separately on pg. 17.

PLEASE NOTE: If you are mounting disc brakes on fiberglass or wooden wheels without channel, rubber, and steel, you can expect some rattle due to excessive vibration. Feel free to call with questions!

Disc Brake Kit w/ Covers for Regular Axles 5530-DC

Clamp-on bracket. Fits 1" or 1 1/8" axle.



Disc Brake Kit for Regular Axles 5530

Clamp-on bracket. Fits 1" or 1 1/8" axle



Disc Brake Kit for CMS 1 1/4" Hub 5533

For gear with weld-on caliper bracket (not included).



Disc Brake Kit for 8 Bolt Hub 5534

For gear with weld-on caliper bracket (not included).



Also Available: Disc Brake Kits for Farmerstown Axle Systems
5535 Fits 1 1/4" Farmerstown Axle **5536** Fits 1 1/2" Farmerstown Axle

Metal Disc 1/4" x 9 1/2". Zinc plated steel.



5041 For regular hub wheels



5043 For CMS 1 1/4" hub



Brakleen 5247
Used to clean brake rotors and calipers.



Aluminum Disc Mount 5048
For mounting discs to aluminum wheels.



Aluminum Disc Mount 5049
For mounting discs to metal, wooden & fiberglass wheels.



Disc Covers 5100-P
High-gloss black plastic.



Disc Cover Rubber 5186
For #5100 disc covers.

CMS Disc Brakes now compatible with... TROOPER by ROADEdge



Mounting holes in disc brakes are now provided for quick installation of the Trooper speedometer.



For more information, please contact Dashing Woodworks
 717-808-4315 405 Cains Road Gap, PA 17527



Caliper - 1/4" **5045**
Disc brake wheel caliper



Caliper Pads
5046 Set of 4



Brake Pad Shims
5098 Set of 4. Available
in .025" or .050" thickness.

Caliper Brackets



Caliper Bracket
5340 For 1" and 1 1/8" axle. Powder coated black. Tightens against all 4 sides of the axle, creating less movement caused by vibration.



Caliper Bracket w/ Disc Cover Attachment **5342**
For 1" and 1 1/8" axle. Powder coated black. Tightens against all 4 sides of the axle, creating less movement caused by vibration.

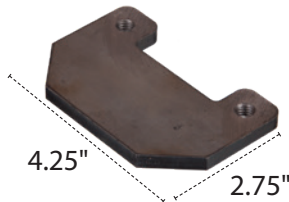

5116 3/8" raw steel

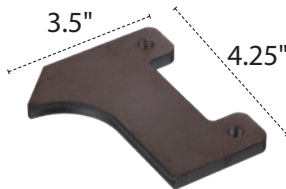

5118 3/8" raw steel

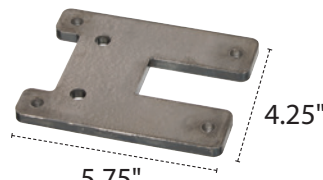

5113 For disc cover.
3/8" raw steel.

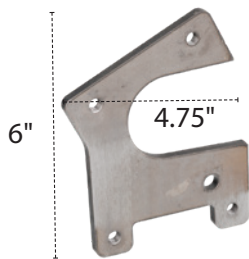

5343 For disc cover.
3/8" raw steel for torsion arm.



Rebuilding a
CMS caliper?
Here's what
you need!

CMS part numbers
are listed in green.

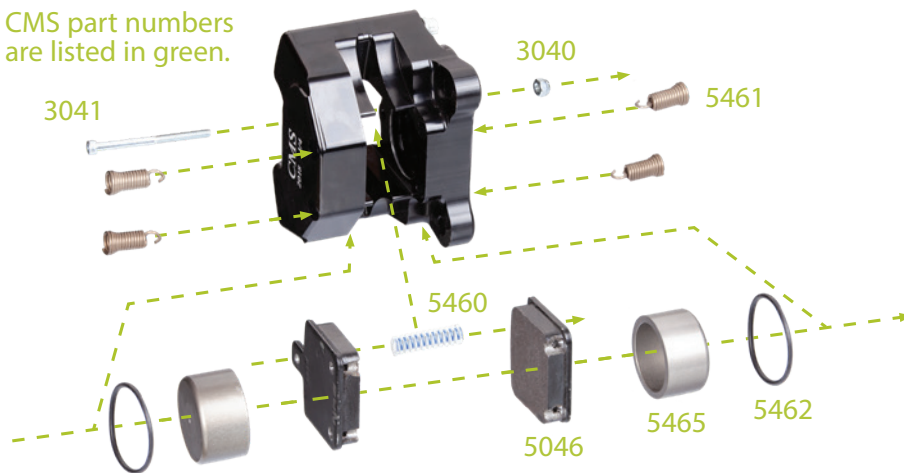

Helpful
Tool

The perfect solution for installing pads in the CMS Caliper!



Disc Brake Caliper
Pad Assembly Tool
5244



1 Put springs #**5461**
into holes in caliper.

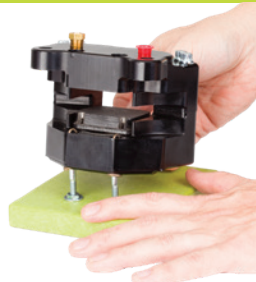

2 Set caliper on
assembly tool.



3 Push down on caliper &
slide pad in until both
springs hook into pad.



4 Repeat for
second pad.

Master Cylinder Assembly

5558 1" with check valve (for drum)

5559 1" w/o check valve (for disc)

5560 1 1/8" w/o check valve (for disc)



Master Cylinder Rebuild Kit
5561-RB



1/2" Igus Bearing 5185
Used to increase durability at the pivot point in the master cylinder.



Pedal Arm Spring 5549
Black zinc coated



Replacement Cap for MC 5564



Master Cylinder Bracket Only 5566
Powder coated black



Brake Eyelette 5020
Brake pedal ball joint.



Pedal Cap 5127
Aluminum, 3/8" thread hole

Master Cylinder Only



5561 1" w/o check valve (for disc)
5562 1 1/8" w/o check valve (for disc)
5563 1" with check valve (for drum)

These three items may be used to clean out disc bolt threads on CMS 1 1/4" hub wheels.



6mm-10 Tap 5439



6mm Thread Cleaner 5438



6M x 1.0 Thread Form 5440

Stainless Steel Bleeder Screw w/ Brass Bushing 5469



3/8" Nylon Lock Nut 3018
Zinc plated



#10-24 x 2 1/2" Hex Cap Screw Bolt Grade 5 3041



Bleeder Screw 5468
Stainless steel



Caliper Shim 5097
3/8" ID x .020" thick



#10-24 Nylon Lock Nut 3040



Bleeder Screw Bushing 5467
Brass



Split Washer 5/16" 3100
Stainless steel



Caliper Spring 5460
3/8" x 1 1/4" spring goes between pads.

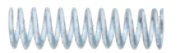

3/8" x 1" Grade 8 Hexhead Bolt 3027



Split Washer 3/8" 3101
Stainless steel



Caliper Spring 5461
Keeps tension on pads to eliminate rattle.



3/8" x 1 1/4" Grade 8 Hexhead Bolt 3028
For calipers



Flat Washer 3/8" 3102
Stainless steel



Socket Head Cap Screw Grade 5 - 5/16" x 1 1/4" 3031



O-Ring 5462
Caliper piston O-ring



Socket Head Cap Screw Grade 5 - 5/16" x 3/4" 3032



O-Ring Lubricant 5463
Use on pistons and o-rings when rebuilding a disc brake caliper

Caliper Piston 5465
For 1/4" caliper



Socket Head Cap Screw 6mm x 3/4" 3033
Stainless steel



Brake Fittings



3/16" Brake Tubing

High pressure brake tubing is available in 100, 500 & 2000-ft. rolls.

- 5420per foot
- 5420-100.....100 ft. roll
- 5420-500.....500 ft. roll
- 5420-2000.....2,000 ft. roll

Tubing Cutter 5246

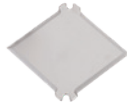

Replacement Blade 5245



Loctite Thread Locker 263
5450 To be used on disc fasteners. 1.69 oz.



Loctite Thread Sealant 545
5451 Recommended for use on disc brakes or air bag fittings. Use in place of Teflon tape. 1.69 oz.



3/16" Tubing Clip
5184



Self Drilling Screw
Panhead #8 x 1/2"
3035
Stainless steel

Compression Fittings

- Fits hydraulic disc or drum brakes.
- Solid brass (no-rust)



Compression Tee
5421



Compression Elbow 5422
Fits master cylinder & disc brake calipers.



Compression Straight 5423
Fits drum brakes.



Compression Nut 5424



Brake Lock Valve
5430



Mounting Bracket
5393 for Brake Lock Valve & Air Valve



Compression Elbow 5422

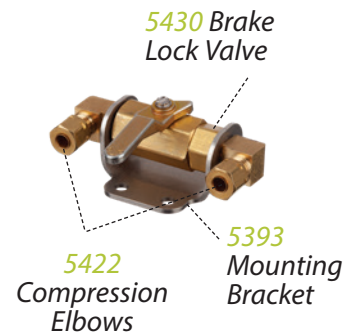

Items sold separately.
Shown assembled for reference.



PENNSYLVANIA EXEMPTION CERTIFICATE

- STATE AND LOCAL SALES AND USE TAX
- STATE 6% AND LOCAL 1% HOTEL OCCUPANCY TAX
- PUBLIC TRANSPORTATION ASSISTANCE TAXES AND FEES (PTA)
- VEHICLE RENTAL TAX (VRT)
- ADDITIONAL LOCAL, CITY, COUNTY HOTEL TAX **

This form cannot be used to obtain a Sales Tax Account ID, PTA Account ID or Exempt Status.

(Please Print or Type)
**Read Instructions
On Reverse Carefully**

THIS FORM MAY BE PHOTOCOPIED – VOID UNLESS COMPLETE INFORMATION IS SUPPLIED

- CHECK ONE:** **PENNSYLVANIA TAX UNIT EXEMPTION CERTIFICATE** (USE FOR ONE TRANSACTION)
 PENNSYLVANIA TAX BLANKET EXEMPTION CERTIFICATE (USE FOR MULTIPLE TRANSACTIONS)

Name of Seller, Vendor or Lessor
 Carriage Machine Shop, LLC

Street 250 Maple Ave	City Bird-in-Hand	State PA	ZIP Code 17505
-------------------------	----------------------	-------------	-------------------

NOTE: Do not use this form for claiming an exemption on the registration of a vehicle. To claim an exemption from tax for a motor vehicle, trailer, semi-trailer or tractor with the PA Department of Transportation, Bureau of Motor Vehicles, use one of the following forms:

- FORM MV-1**, Application for Certificate of Title (first-time registrations)
- FORM MV-4ST**, Vehicle Sales and Use Tax Return/Application for Registration (other registrations)

Property and services purchased or leased using this certificate **are exempt** from tax because: (Select the appropriate paragraph from the back of this form, check the corresponding block below and insert information requested).

- 1. Property or services will be used directly and predominately by purchaser in performing purchaser's operation of: _____
- 2. Purchaser is a/an: _____ holding Sales Tax Exemption Number _____
- 3. Property will be resold under Account ID _____ (If purchaser does not have a PA Sales Tax Account ID, include a statement under Number 8 explaining why a number is not required).
- 4. Property or services will be used directly and predominately by purchaser performing a public utility service.
 PA Public Utility Commission PUC Number _____ and/or U.S. Department of Transportation MC/MX _____
- 5. Exempt wrapping supplies, Account ID _____ (If purchaser does not have a PA Sales Tax Account ID, include a statement under Number 8 explaining why a number is not required).
- 6. Canned computer software purchased by a financial institution subject to the Bank and Trust Company Shares Tax (Article VII) or the Mutual Thrift Institutions Tax (Article XV).
- 7. Canned computer software licenses that are billed to a PA address but used outside of PA. The total number of software licenses purchased for invoice # _____ is _____. The total number of users accessing and using the software outside PA is _____.
- 8. Other _____
 (Explain in detail. Additional space on reverse side).

I am authorized to execute this certificate and claim this exemption. Misuse of this certificate by seller, lessor, buyer, lessee or their representative is punishable by fine and imprisonment.

Name of Purchaser or Lessee	Signature	EIN	Date
Street	City	State	ZIP Code

- 1. ACCEPTANCE AND VALIDITY:**
 For this certificate to be valid, the seller/lessor shall exercise good faith in accepting this certificate, which includes: (1) the certificate shall be completed properly; (2) the certificate shall be in the seller/lessor's possession within 60 days from the date of sale/lease; (3) the certificate does not contain information which is knowingly false; and (4) the property or service is consistent with the exemption to which the customer is entitled. For more information, refer to Exemption Certificates, Title 61 PA Code §32.2. An invalid certificate may subject the seller/lessor to the tax.
- 2. REPRODUCTION OF FORM:**
 This form may be reproduced but shall contain the same information as appears on this form.
- 3. RETENTION:**
 The seller or lessor must retain this certificate for at least four years from the date of the exempt sale to which the certificate applies.
⚠ IMPORTANT: DO NOT RETURN THIS FORM TO THE PA DEPARTMENT OF REVENUE.
- 4. NONPROFIT EXEMPT ORGANIZATIONS:**
 This form may be used in conjunction with form REV-1715, Exempt Organization Declaration of Sales Tax Exemption, when a purchase of \$200 or more is made by an organization which is registered with the PA Department of Revenue as an exempt organization. These organizations are assigned an exemption number, beginning with the two digits 75 (example: 75000000).



METAL WHEEL ORDER SHEET

CUSTOMER _____
 PO# _____
 PHONE# _____
 ORDER DATE _____
 COMPLETION _____

ADDRESS _____

 SHIP VIA _____

**#5500
REGULAR HUB, LONG SPINDLE**

36" _____
 38" _____
 40" _____
 42" _____

**#5501
FLUSH HUB, SHORT SPINDLE**

36" _____
 38" _____
 40" _____
 42" _____

**#5502
CMS 1 1/4"**

36" _____
 38" _____
 40" _____
 42" _____

BRAKES INSTALLED

DISC ON FRONT _____
 DISC ON REAR _____
 DRUM ON FRONT _____
 DRUM ON REAR _____

RUBBER & RIM OPTIONS

FLAT RUBBER _____
 HALF ROUND RUBBER _____
 RUBBER & FLAT STEEL _____
 LOW PROFILE RUBBER
& FLAT STEEL _____
 RUBBER & HALF ROUND STEEL _____
 LOW PROFILE RUBBER &
HALF ROUND STEEL _____
 NONE _____

NOTES: _____



TORSION GEAR

ORDER SHEET

CUSTOMER _____
 PO# _____
 PHONE# _____
 ORDER DATE _____
 COMPLETION _____

ADDRESS _____

 SHIP VIA _____

GEAR TYPE

AIRBAG or RUBBER SHOCK #5200 _____ AB / RS
 AIRBAG or RUBBER SHOCK #5201 _____ AB / RS
 AIRBAG/SPRING or RUBBER SHOCK #5204 _____ AB / RS
 EZ SPRING #5205 _____
 EZ SPRING #5206 _____
 EZ SPRING #5207 _____
 EZ SPRING #5208 _____
 STRAIGHT AXLE #5210 _____
 STRAIGHT AXLE #5211 _____
 STRAIGHT AXLE (AB or RS) #5212 _____ AB / RS

WHEELS

36 X 40" METAL _____
 38" X 42" METAL _____
 NONE _____
 CUSTOM SIZE _____

WHEEL RIM OPTIONS

FLAT RUBBER _____
 HALF ROUND RUBBER _____
 RUBBER & FLAT STEEL _____
 LP RUBBER & FLAT STEEL _____
 RUBBER & HALF ROUND STEEL _____
 LP RUBBER & HALF ROUND STEEL _____

SHAFTS

PIVOT UP METAL _____
 SINGLE TREE YES NO
 SPRING TREE CHROME BLACK _____

SHAFT ATTACHMENTS

PLATE FOR PIVOT UP _____
 TABS FOR REGULAR SHAFTS _____
 CUSTOM ATTACHMENT _____

BRAKES

DISC ON FRONT _____
 DISC ON REAR _____
 DISC COVERS _____
 DRUM ON FRONT _____
 DRUM ON REAR _____
 NONE _____

MASTER CYLINDER

1" w/o CHECK VALVE (DISC) #5559 _____
 1" w/ CHECK VALVE (DRUM) #5558 _____
 OTHER _____

AXLE SPINDLES

CMS 1 1/4" _____
 LONG SPINDLE 1 1/8" _____
 SHORT SPINDLE 1 1/8" _____

ALUMINUM STRIP (AIR BAG ONLY)

REGULAR _____
 SPLIT _____

AIR COMPRESSOR KIT

W/ REGULAR GAUGES _____
 W/ FACEMOUNT GAUGES _____
 W/ S.S. GAUGE MOUNTING PLATE _____

BODY BOX SIZE (AIRBAG) _____

SPRING CENTERS (EZ SPRING) _____

5TH WHEEL STOP YES NO

WELD ON TABS FOR AXLE LIGHTS YES NO

NOTES: _____



CARRIAGE PARTS

ORDER SHEET

CUSTOMER _____
PO# _____
PHONE# _____
ORDER DATE _____
COMPLETION _____

ADDRESS _____

SHIP VIA _____

QTY	PART#	DESCRIPTION	PRICE	TOTAL

***ASK for these products
at your local coach shop.***



Keep Smiling!



250 Maple Ave. Bird-in-Hand, PA 17505

***Please call for technical questions.
Wholesale accounts: Call for quantity pricing.***